

Robotics

Compact Catalogue



SHAPING THE NEXT GENERATION OF SMART AUTOMATION

Increased Sustainability

monitor, track and trace processes to improve overall efficiency

Cost Savings

save money on operational costs, as well as reduce the risk of human error

Improved Quality

ensure consistent and improved quality in products and services, while reducing defects and errors

Greater Scalability

handle higher volumes of work by replicating solutions after the first development

Enhanced Safety

reduce the need for humans to perform dangerous or hazardous tasks

Increased Innovation

leverage automation to create new processes and products

Customer Satisfaction

improve response consistency in customer service, leading to increased customer satisfaction

MyCo collaborative robot family



Model	MyCo-3-0.59	MyCo-3.5-0.95	MyCo-5-0.80	MyCo-8-1.30	MyCo-10-1.00	MyCo-15-1.30
Weight	18kg	26kg	25kg	45kg	43kg	60kg
Payload	3kg	3.5kg	5kg	8kg	10kg	15kg
Reach	590mm	950mm	800mm	1300mm	1000mm	1300mm
Power Consumption	"100W Typical Application"	"180W Typical Application"	"180W Typical Application"	"350W Typical Application"	"350W Typical Application"	"600W Typical Application"
Joint Range	"J1, J4, J6 ±360° J2 ±135° J3 ±150° J5 ±147°"	"J1, J4, J6 ±360° J2 ±135° J3 ±153° J5 ±180°"	"J1, J4, J6 ±360° J2 ±135° J3 ±153° J5 ±180°"	"J1, J4, J6 ±360° J2 ±135° J3 ±153° J5 ±180°"	"J1, J4, J6 ±360° J2 ±135° J3 ±153° J5 ±180°"	"J1, J4, J6 ±360° J2 ±135° J3 ±153° J5 ±180°"
Joint Speed	"J1-J4 180°/s J5-J6 200°/s"	"J1-J4 180°/s J5-J6 200°/s"	"J1-J4 180°/s J5-J6 200°/s"	"J1-J2 100°/s J3-J4 150°/s J5-J6 180°/s"	"J1-J2 100°/s J3-J4 150°/s J5-J6 180°/s"	"J1-J2 80°/s J3-J4 120°/s J5-J6 150°/s"
Tool Speed	2m/s	3m/s	3m/s	2.5m/s	2m/s	2m/s
Repeatability	±0.02mm	±0.02mm	±0.02mm	±0.03mm	±0.03mm	±0.05mm
Degree of Freedom	6					
Dust and Water Protection Class	IP54 (IP66 optional)					
UL94 Classification	V0					
Mounting Position	Floor / Ceiling / Inclined Plane / Wall					
End I/O Port	Digital input: 3, Digital output: 3, Analog input: 2					
Control box I/O port	Digital input: 16, Digital output: 16, Analog input: 2, Analog output: 2					
I/O Source	24V 2A					
Communication	TCP/IP, ModbusTCP, Profinet (Optional), Ethernet/IP (Optional)					
Programming	Graphical Programming, Remote calling interface					
Collaborative Operation	10 advanced security configuration functions					
Main Material	Aluminium Alloy					
Working Temperature	0-50°C					
Power Input	100-240V AC, 50-60Hz					
Cable	Cable to control box: 5m, Cable to teach pendant: 5m					

Collaborative and SE robots

Collaborative robots



Sensitive Environments robot



Model	Racer-5-0.80 COBOT	Racer-5 SE
Structure / No. of axes	Anthropomorphic / 6 axes	6 axes
Maximum wrist payload	5 kg	5 kg
Nominal wrist load	1 kg	1 kg
Maximum horizontal reach	809 mm	630mm (2.07ft) - 809mm (2.65ft)
Torque on axis 4	8,83 Nm	8,83 Nm
Torque on axis 5	8,83 Nm	8,83 Nm
Torque on axis 6	4,91 Nm	4,91 Nm
Admissible inertia on axis 4*	0,42 kg x m ²	0,42 kg x m ²
Admissible inertia on axis 5*	0,42 kg x m ²	0,42 kg x m ²
Admissible inertia on axis 6*	0,18 kg x m ²	0,18 kg x m ²
Motion range (Max Speed)	Axis 1 Axis 2 Axis 3 Axis 4 Axis 5 Axis 6 +/- 170° (360 °/s) ** -64° / +114° (300 °/s) ** -150° / +60° (330 °/s) ** +/- 200° (500 °/s) ** -105° / +100° (500 °/s) ** +/- 2700° (800 °/s) **	+/- 170° (400 °/s) ** -95° / +135° (360 °/s) -85° / +135° (360 °/s) -155° / +90° (400 °/s) ** +/- 200° (500 °/s) ** +/- 125° (500 °/s) ** +/- 2700° (800 °/s) **
Repeatability	+/-0,03 mm	+/-0,03 mm (1.18 mil)
Tool coupling flange ISO	/	/
Robot weight	34 kg	33 kg (73 lb) - 35 kg (77 lb)
Features of the tool coupling Robot wrist	ISO 9409 - 1 - A 25	ISO 9409 - 1 - A 25
Motors	AC Brushless	AC Brushless
Position measurement system	Encoder	Encoder
Total power installed	/	/
Protection degree	IP54	IP67
Mounting position	Floor, wall, ceiling	Floor / Ceiling / Wall **
Working temperature	5°C / +40°C	from 0°C to +45°C (from +32°F to +113°F)
Storage temperature	-10°C / 55°C	from -10°C to +55°C (from +14°F to +131°F)
Robot color	/	/
Maximum temperature gradient	1,5°C/min	1,5°C/min
Maximum linear speed	/	/
Maximum collaborative linear speed	/	/
ISO 14644-1 CleanRoom Certification assessment	/	ISO 6***
Use of Food Approved gaskets	/	Yes
Use of NSF H1	/	Yes

* Not allowed with maximum load

** Maximum speed

*** Base vertical cable output available (option)

In the case of angle mounted Robot, the stroke of axis 1 must be limited according to the inclination of the angle itself and the payload. ** Not allowed with maximum load * Guaranteed up to 80% angular speed of the Robot axes

(Axis 1: max. 320°/s; Axis 2: max. 288°/s; Axis 3: max. 320°/s; Axis 4: max. 400°/s; Axis 5: max. 400°/s; Axis 6: max. 640°/s).

Weareable Robotics

The MATE exoskeletons generate a steady reduction at the lumbar or shoulder muscle activation during overhead activities and manual handling of weights from the ground, improving ergonomics posture and reducing muscular strain.



MATEXT GO

Professional exoskeleton designed to enhance worker well-being during repetitive tasks by providing natural support to the shoulders and arms. Lightweight, comfortable, and made with high-quality materials and engineering solutions, it is certified as Personal Protective Equipment (PPE – Category II) in accordance with EU Regulation 2016/425.



MATEXB

Non-powered exoskeleton for reducing the fatigue at the lumbar district for workers engaged in moving weights. It supports the user while working in different static positions or during repetitive lifting of loads.

Industrial robots



Robots

		Small					
Model		RACER-3-0.63	RACER-5-0.63	RACER-5-0.80	RACER-7-1.4	S-13	S-18
Number of axes		6	6	6	6	6	6
Maximum wrist payload		3 kg	5 kg	5 kg	7 kg	13 kg	18 kg
Additional load on forearm		-	-	-	10 kg	10 kg	10 kg
Maximum horizontal reach		630 mm	630 mm	809 mm	1436 mm	1960 mm	1730 mm
Torque on axis 4		7.36 Nm	8.83 Nm	8.83 Nm	13 Nm	35 Nm	50 Nm
Torque on axis 5		7.36 Nm	8.83 Nm	8.83 Nm	13 Nm	35 Nm	50 Nm
Torque on axis 6		4.41 Nm	4.91 Nm	4.91 Nm	7.5 Nm	22 Nm	30 Nm
Motion range (Max Speed)	Axis 1	+/- 170° (430 °/s)	+/- 170° (400 °/s)	+/- 170° (360 °/s)	+/- 165° (220 °/s)	+/- 180° (205 °/s)	+/- 180° (205 °/s)
	Axis 2	-95° / +135° (450 °/s)	-95° / +135° (360 °/s)	-95° / +135° (300 °/s)	-85° / +155° (250 °/s)	-90° / +160° (180 °/s)	-90° / +160° (180 °/s)
	Axis 3	-155° / +90° (500 °/s)	-155° / +90° (400 °/s)	-155° / +90° (330 °/s)	0° / -168° (300 °/s)	-175° / +90° (260 °/s)	-175° / +90° (260 °/s)
	Axis 4	+/- 200° (600 °/s)	+/- 200° (500 °/s)	+/- 200° (500 °/s)	+/- 210° (600 °/s)	+/- 200° (400 °/s)	+/- 200° (400 °/s)
	Axis 5	+/- 125° (600 °/s)	+/- 125° (500 °/s)	+/- 125° (500 °/s)	+/- 135° (600 °/s)	+/- 125° (400 °/s)	+/- 123° (250 °/s)
	Axis 6	+/- 2700° (900 °/s)	+/- 2700° (800 °/s)	+/- 2700° (800 °/s)	+/- 2700° (650 °/s)	+/- 2700° (635 °/s)	+/- 2700° (635 °/s)
Repeatability		0.02 mm	0.03 mm	0.03 mm	0.03 mm	+/- 0.03 mm	+/- 0.03 mm
Tool coupling flange ISO		9409-1 - A 25	9409-1 - A 25	9409-1 - A 25	9409-1 - A 40	ISO 9409-1-A50	ISO 9409-1-A50
Robot weight		30 kg	30 kg	32 kg	180 kg	270 kg	265 kg
Protection class		IP54	IP54	IP54	IP54	IP65 (wrist IP68)	IP65 (wrist IP68)
Mounting position		Floor Ceiling Wall	Floor Ceiling Wall	Floor Ceiling Wall	Floor Ceiling Wall Sloped (45° max)	Floor Ceiling Wall Inclined Plane	Floor Ceiling Wall Inclined Plane
Operating area type		Type 1	Type 1	Type 1	Type 2	Type 2	Type 1
Operating areas	A	1081 mm	1081 mm	1124 mm	1716 mm	2273 mm	2039 mm
	B	630 mm	630 mm	809 mm	1436 mm	1959 mm	1725 mm
	C	37 mm	37 mm	8 mm	412 mm	1123 mm	1039 mm
	D	530 mm	530 mm	708 mm	1130 mm	1659 mm	1425 mm
	E	136 mm	136 mm	286 mm	801 mm	1299 mm	1065 mm
	F	-	-	-	-	-	-
		Base vertical cable output available			ARC version available		

		Medium		
Model		NJ-16-3.1	NJ-40-2.5	NJ-60-2.2
Number of axes		6	6	6
Maximum wrist payload		16 kg	40 kg	60 kg
Additional load on forearm		12 kg	35 kg	20 kg
Maximum horizontal reach		3108 mm	2503 mm	2258 mm
Torque on axis 4		43 Nm	167 Nm	221 Nm
Torque on axis 5		43 Nm	167 Nm	221 Nm
Torque on axis 6		23 Nm	98 Nm	118 Nm
Motion range (Max Speed)	Axis 1	+/- 180° (170 °/s)	+/- 180° (170 °/s)	+/- 180° (170 °/s)
	Axis 2	-60° / +125° (150 °/s)	-60° / +125° (150 °/s)	-60° / +125° (150 °/s)
	Axis 3	0° / -170° (165 °/s)	0° / -165° (165 °/s)	0° / -165° (165 °/s)
	Axis 4	+/- 2700° (265 °/s)	+/- 2700° (265 °/s)	+/- 2700° (265 °/s)
	Axis 5	+/- 120° (250 °/s)	+/- 135° (250 °/s)	+/- 123° (250 °/s)
	Axis 6	+/- 2700° (340 °/s)	+/- 2700° (550 °/s)	+/- 2700° (340 °/s)
Repeatability		0.10 mm	0.06 mm	0.06 mm
Tool coupling flange ISO		9409-1 - A63	9409-1 - A100	9409-1 - A100
Robot weight		680 kg	655 kg	645 kg
Protection class		IP65 (wrist IP67)	IP65 (wrist IP67)	IP65 (wrist IP67)
Mounting position		Floor Ceiling Sloped (45° max)	Floor Ceiling Sloped (45° max)	Floor Ceiling Sloped (45° max)
Operating area type		Type 2	Type 2	Type 2
Operating areas	A	3258 mm	2653 mm	2408 mm
	B	3108 mm	1959 mm	1725 mm
	C	2576 mm	2165 mm	1918 mm
	D	1088 mm	720 mm	686 mm
	E	1625 mm	1187 mm	941 mm
	F	-	-	-
		ARC version available	Off-wrist version available	

		Special				
Model		PAL-180-3.1	PAL-260-3.1	PAL-470-3.1	NJ-100-3.2 PRESS	NJ-100-3.7 SH PRESS
Number of axes		4	4	5	6	6
Maximum wrist payload		180 kg	260 kg	470 kg	100 kg	130 kg
Additional load on forearm		25 kg	50 kg	25 kg	50 kg	15 kg
Maximum horizontal reach		3100 mm	3100 mm	3100 mm	3209 mm	3741 mm
Torque on axis 4		-	-	-	638 Nm	1225 Nm
Torque on axis 5		-	-	-	638 Nm	1225 Nm
Torque on axis 6		-	-	-	280 Nm	648 Nm
Motion range (Max Speed)	Axis 1	+/- 180° (120 °/s)	+/- 180° (120 °/s)	+/- 180° (85 °/s)	+/- 180° (120 °/s)	+/- 180° (120 °/s)
	Axis 2	-49° / +95° (100 °/s)	-49° / +95° (80 °/s)	-49° / +75° (85 °/s)	-49° / +95° (108 °/s)	-60° / -170° (90 °/s)
	Axis 3	-68° / -208° (110 °/s)	-68° / -208° (110 °/s)	-45° / -205° (85 °/s)	-222° / -68° (120 °/s)	-292° / -21° (112 °/s)
	Axis 4	-	-	Axis bound to balance	+/- 200° (190 °/s)	+/- 2700° (180 °/s)
	Axis 5	-	-	-	+/- 120° (190 °/s)	+/- 125° (175 °/s)
	Axis 6	+/- 2700° (280 °/s)	+/- 2700° (260 °/s)	+/- 2700° (180 °/s)	+/- 2700° (250-275 °/s)	+/- 2700° (250 °/s)
Repeatability		0.10 mm	0.10 mm	0.15 mm	0.17 mm	0.20 mm
Tool coupling flange ISO		9409-2-200-6-M12	9409-2-200-6-M12	9409-1 - A 200	9409-1 - A 125	9409-1 - A 160
Robot weight		1213 kg	1213 kg	2310 kg	1250 kg	1520 kg
Protection class		IP65	IP65	IP65	IP44 (wrist IP65)	IP44 (wrist IP65)
Mounting position		Floor - - - - -	Floor - - - - -	Floor - - - Shelf	Floor - - - -	- - - Shelf
Operating area type		Type 3	Type 3	Type 3	Type 3	Type 4
Operating areas	A	3147 mm	3147 mm	3522 mm	2780 mm	3391 mm
	B	3099 mm	3099 mm	3050 mm	3209 mm	3741 mm
	C	962 mm	962 mm	480 mm	1035 mm	692 mm
	D	1182 mm	1182 mm	793 mm	642 mm	712 mm
	E	-	-	-	-	2386 mm
	F	-	-	-	-	850 mm

SCARA robots

Model	REBEL-S6-0.45	REBEL-S6-0.60	REBEL-S6-0.60C	REBEL-S6-0.75	REBEL-S6-0.75C
Payload	6 kg				
Horizontal reach (radius)	450 mm	600 mm		750 mm	
Vertical reach (Z-stroke)	200 mm				
Repeatability (X-Y)	0.02 mm				
Available protection classes	IP10 (IP54 Option)				
Outer / Inner diameter of ball screw/spline	20 mm / 14 mm				
Z axis down force (long-time)	160 N				
Robot weight	20 kg				
Mounting position	Floor / Wall	Wall / Ceiling	Floor / Wall	Wall / Ceiling	Wall / Ceiling



Operating area SCARA

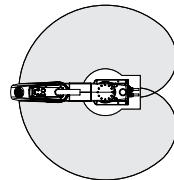

Operating area Type 1

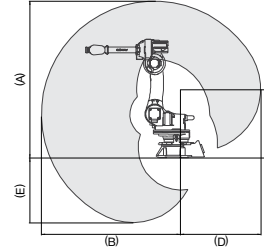

Operating area Type 2

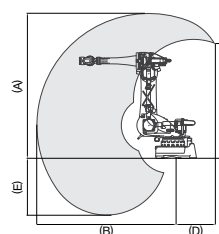

Operating area Type 3

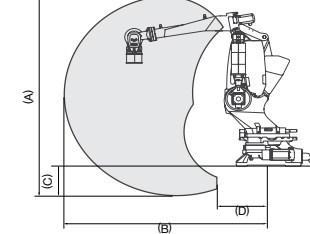

Operating area Type 4

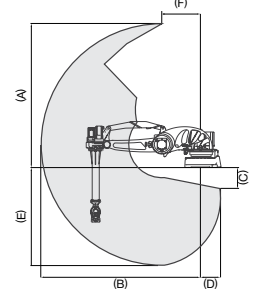

Industrial robots



Robots

		High payload														
Model		NJ-110-3.0	NJ-130-2.0	NJ-130-2.6	NJ-165-3.0	NJ-165-3.4 SH	NJ-210-3.1 SH	NJ-220-2.7	NJ-290-3.0	NJ-370-2.7	NJ-370-3.0	NJ-420-3.0	NJ-450-2.7	NJ-500-2.7	NJ-650-2.7	
Number of axes		6	6	6	6	6	6	6	6	6	6	6	6	6	6	
Maximum wrist payload		110 kg	130 kg	130 kg	165 kg	165 kg	210 kg	220 kg	290 kg	370 kg	370 kg	420 kg	450 kg	500 kg	650 kg	
Additional load on forearm		50 kg	50 kg	50 kg	50 kg	25 kg	25 kg	50 kg	50 kg	50 kg	50 kg	50 kg	50 kg	50 kg	50 kg	
Maximum horizontal reach		2980 mm	2050 mm	2616 mm	3000 mm	3450 mm	3151 mm	2701 mm	2997 mm	2703 mm	2997 mm	2997 mm	2703 mm	2703 mm	2703 mm	
Torque on axis 4		638 Nm	638 Nm	638 Nm	1230 Nm	1089 Nm	1177 Nm	1230 Nm	1668 Nm	2109 Nm	2109 Nm	2550 Nm	2550 Nm	2550 Nm	3060 Nm	
Torque on axis 5		638 Nm	638 Nm	638 Nm	1230 Nm	804 Nm	1177 Nm	1230 Nm	1668 Nm	2109 Nm	2109 Nm	2550 Nm	2550 Nm	2550 Nm	3060 Nm	
Torque on axis 6		291 Nm	314 Nm	314 Nm	712 Nm	411 Nm	677 Nm	712 Nm	1177 Nm	1177 Nm	1569 Nm	1569 Nm	1569 Nm	1569 Nm	1766 Nm	
Motion range (Max Speed)	Axis 1	+/- 180° (110 %/s)	+/- 180° (115 %/s)	+/- 180° (110 %/s)	+/- 180° (110 %/s)	+/- 180° (85 %/s)	+/- 180° (110 %/s)	+/- 180° (100 %/s)	+/- 180° (80 %/s)	+/- 180° (85 %/s)	+/- 180° (85 %/s)	+/- 180° (85 %/s)	+/- 180° (85 %/s)	+/- 180° (85 %/s)	+/- 180° (75 %/s)	
	Axis 2	+85° / -75° (110 %/s)	-80° / +125° (110 %/s)	+85° / -75° (110 %/s)	-85° / +180° (90 %/s)	-50° / +170° (90 %/s)	-50° / +170° (90 %/s)	-85° / +75° (90 %/s)	+/- 75° (85 %/s)	+75° / -60° (85 %/s)	+75° / -60° (85 %/s)	+75° / -60° (85 %/s)	+75° / -60° (85 %/s)	+75° / -60° (85 %/s)	+75° / -60° (75 %/s)	
	Axis 3	-10° / -256° (110 %/s)	0° / +165° (110 %/s)	-10° / -256° (110 %/s)	-10° / -256° (110 %/s)	-18,8° / -288° (110 %/s)	-21,3° / -288° (110 %/s)	-10° / -256° (110 %/s)	0° / -220° (90 %/s)	-10° / -231° (85 %/s)	-10° / -231° (85 %/s)	-10° / -231° (85 %/s)	-10° / -231° (85 %/s)	-10° / -231° (85 %/s)	-10° / -231° (85 %/s)	-10° / -231° (75 %/s)
	Axis 4	+/- 280° (190 %/s)	+/- 200° (200 %/s)	+/- 280° (190 %/s)	+/- 2700° (130 %/s)	+/- 2700° (130 %/s)	+/- 2700° (130 %/s)	+/- 2700° (130 %/s)	+/- 2700° (105 %/s)	+/- 2700° (90 %/s)	+/- 2700° (90 %/s)	+/- 2700° (90 %/s)	+/- 2700° (90 %/s)	+/- 2700° (90 %/s)	+/- 2700° (90 %/s)	+/- 2700° (90 %/s)
	Axis 5	+/- 120° (190 %/s)	+/- 120° (190 %/s)	+/- 120° (190 %/s)	+/- 125° (130 %/s)	+/- 125° (130 %/s)	+/- 125° (130 %/s)	+/- 125° (130 %/s)	+/- 125° (105 %/s)	+/- 125° (90 %/s)	+/- 125° (90 %/s)	+/- 125° (90 %/s)	+/- 125° (90 %/s)	+/- 125° (90 %/s)	+/- 125° (90 %/s)	+/- 125° (90 %/s)
	Axis 6	+/- 2700° (230 %/s)	+/- 2700° (230 %/s)	+/- 2700° (230 %/s)	+/- 2700° (195 %/s)	+/- 2700° (195 %/s)	+/- 2700° (195 %/s)	+/- 2700° (195 %/s)	+/- 2700° (195 %/s)	+/- 2700° (120 %/s)	+/- 2700° (120 %/s)	+/- 2700° (120 %/s)	+/- 2700° (120 %/s)	+/- 2700° (120 %/s)	+/- 2700° (120 %/s)	+/- 2700° (120 %/s)
Repeatability		0.07 mm	0.07 mm	0.07 mm	0.09 mm	0.10 mm	0.10 mm	0.08 mm	0.15 mm	0.15 mm	0.15 mm	0.15 mm	0.15 mm	0.15 mm	0.15 mm	
Tool coupling flange ISO		9409 - 1 - A 125	9409 - 1 - A 125	9409 - 1 - A 125	9409 - 1 - A 160	9409-1-A.160/200	9409-1-A.160	9409 - 1 - A 160	9409-1-200-6-M12	9409-1-200-6-M12	9409-1-200-6-M12	9409-1-200-6-M12	9409-1-200-6-M12	9409-1-200-6-M12	9409-1-200-6-M12	
Robot weight		1070 kg	740 kg	1050 kg	1240 kg	1430 kg	1415 kg	1220 kg	2150 kg	2100 kg	2450 kg	2450 kg	2400 kg	2400 kg	2450 kg	
Protection class		IP65 (wrist IP67)	IP65 (wrist IP67)	IP65 (wrist IP67)	IP65 (wrist IP67)	IP65 (wrist IP67)	IP65 (wrist IP67)	IP65 (wrist IP67)	IP65 (wrist IP67)	IP65 (wrist IP67)	IP65 (wrist IP67)	IP65 (wrist IP67)	IP65 (wrist IP67)	IP65 (wrist IP67)	IP65 (wrist IP67)	
Mounting position		Floor Ceiling -	Floor Ceiling Sloped	Floor Ceiling -	Floor Ceiling -	- - Shelf	- - Shelf	Floor Ceiling -	- - -	Floor - -	Floor - -	Floor - -	Floor - -	Floor - -	Floor - -	
Operating area type		Type 2	Type 2	Type 2	Type 2	Type 4	Type 4	Type 2	Type 2	Type 2	Type 2	Type 2	Type 2	Type 2	Type 2	
Operating areas	A	3460 mm	2200 mm	3097 mm	3430 mm	3100 mm	2801 mm	3131 mm	3680 mm	3382 mm	3680 mm	3680 mm	3382 mm	3382 mm	3382 mm	
	B	2980 mm	2050 mm	2616 mm	3000 mm	3151 mm	3151 mm	2701 mm	2997 mm	2703 mm	2997 mm	2997 mm	2703 mm	2703 mm	2703 mm	
	C	2642 mm	1690 mm	2261 mm	2600 mm	449 mm	547 mm	2286 mm	2922 mm	2617 mm	3195 mm	3195 mm	2895 mm	2895 mm	2895 mm	
	D	757 mm	720 mm	824 mm	730 mm	397 mm	93 mm	786 mm	804 mm	804 mm	433 mm	433 mm	486 mm	486 mm	486 mm	
	E	783 mm	733 mm	404 mm	738 mm	2100 mm	1800 mm	425 mm	119 mm	119 mm	119 mm	119 mm	-181 mm (****)	-181 mm (****)	-181 mm (****)	
	F	-	-	-	-	850 mm	850 mm	-	-	-	-	-	-	-	-	-



Operating area Type 2

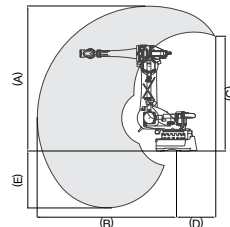

Operating area Type 4

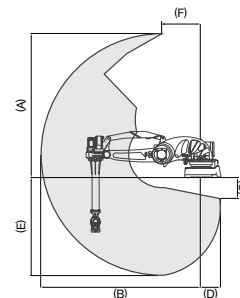

Industrial robots



Robots

Model	Hollow Wrist					Hollow Forearm				
	NJ4-110-2.2	NJ4-220-3.0	NJ4-270-2.7	NJ4-165-3.4 SH	NJ4-210-3.1 SH	N-170-3.0 / N-170-3.0 F	N-170-2.9 CEILING	N-220-2.7 / N-220-2.7 F	N-220-2.6 CEILING	
Number of axes	6	6	6	6	6	6	6	6	6	
Maximum wrist payload	110 kg	220 kg	270 kg	165 kg	210 kg	170 kg	170 kg	220 kg	220 kg	
Additional load on forearm	10 kg	25 kg	25 kg	50 kg	25 kg	170 kg	170 kg	270 kg	230 kg	
Maximum horizontal reach	2210 mm	3002 mm	2703 mm	3377 mm	3188 mm	3000 mm	2927 mm	2670 mm	2670 mm	
Torque on axis 4	796 Nm	1320 Nm	1960 Nm	1089 Nm	1315 Nm	1273 Nm	1273 Nm	1273 Nm	1273 Nm	
Torque on axis 5	609 Nm	950 Nm	1457 Nm	804 Nm	952 Nm	1273 Nm	1273 Nm	1273 Nm	1273 Nm	
Torque on axis 6	284 Nm	690 Nm	834 Nm	411 Nm	687 Nm	715 Nm	715 Nm	787 Nm	787 Nm	
Motion range (Max Speed)	Axis 1	+/- 180° (155 %/s)	+/- 180° (90 %/s)	+/- 180° (90 %/s)	+/- 180° (85 %/s)	+/- 180° (110 %/s)	+/- 180° (110 %/s)	+/- 180° (120 %/s)	+/- 180° (120 %/s)	
	Axis 2	-60° / +155° (105 %/s)	-75° / +75° (90 %/s)	-75° / +75° (90 %/s)	-50° / +170° (90 %/s)	+95° / -75° (110 %/s)	-77° / +76° (100 %/s)	-77° / +76° (100 %/s)	-77° / +64° (100 %/s)	
	Axis 3	0° / -165° (150 %/s)	-231° / 0° (90 %/s)	-231° / 0° (90 %/s)	-19,4° / -288° (110 %/s)	-21° / -288° (110 %/s)	-167° / +74° (100 %/s)	-167° / +74° (110 %/s)	-167° / +74° (110 %/s)	
	Axis 4	+/- 200° (200 %/s)	+/- 200° (115 %/s)	+/- 200° (115 %/s)	+/- 200° (130 %/s)	+/- 200° (140 %/s)	+/- 200° (140 %/s)	+/- 200° (140 %/s)	+/- 200° (140 %/s)	
	Axis 5	+/- 200° (165 %/s)	+/- 200° (125 %/s)	+/- 200° (125 %/s)	+/- 200° (140 %/s)	+/- 200° (125 %/s)	+/- 125° (140 %/s)	+/- 125° (140 %/s)	+/- 125° (140 %/s)	
	Axis 6	+/- 200° (265 %/s)	+/- 200° (170 %/s)	+/- 200° (170 %/s)	+/- 200° (170 %/s)	+/- 200° (190 %/s)	+/- 200° (210 %/s)	+/- 200° (210 %/s)	+/- 200° (210 %/s)	
Repeatability	0.07 mm	0.15 mm	0.15 mm	0.10 mm	0.10 mm	0.05 mm	0.05 mm	0.05 mm	0.05 mm	
Tool coupling flange ISO	9409-1-125-6-M10 9409-1-160-6-M10	9409-1 - A 160 9409-1 - A 200	9409-1 - A 160 9409-1 - A 200	9409-1 - A 160 9409-1 - A 200	9409-1 - A 160 9409-1 - A 200	9409-1 - A 125	9409-1 - A 125	9409-1 - A 125	9409-1 - A 125	
Robot weight	685 kg	2005 kg	1975 kg	1430 kg	1460 kg	1277 kg	1277 kg	1250 kg	1250 kg	
Protection class	IP65	IP65	IP65	IP65	IP65	IP65 IP65/IP67 (motors and wrist)	IP65	IP65 IP65/IP67 (motors and wrist)	IP65 IP65/IP67 (motors and wrist)	
Mounting position	Floor	Floor	Floor	-	-	Floor	Floor	Floor	Floor	
	Ceiling	-	-	-	-	Angle	Ceiling	Angle	Ceiling	
	-	-	-	-	-	-	-	-	-	
	-	-	-	Shelf	Shelf	-	-	-	-	
Operating area type	Type 5	Type 5	Type 5	Type 4	Type 4	Type 6	Type 6	Type 6	Type 6	
Operating areas	A	2360 mm		3392 mm 2703	3027 mm	2837 mm	3963,87 mm	3963,87 mm	3076,4 mm	3076,4 mm
	B	2210 mm		mm 2617 mm	3377 mm	3187 mm	3000,84 mm	3000,84 mm	2670,5 mm	2670,5 mm
	C	1856 mm		804 mm	472 mm	535 mm	1825 mm	1825 mm	1850,0 mm	1850,0 mm
	D	712 mm		-181 mm (***)	323 mm	131 mm	651,85 mm	651,85 mm	1552,2 mm	1552,2 mm
	E	893 mm		-	2027 mm	1837 mm	554,93 mm	554,93 mm	222,7 mm	222,7 mm
	F	-		-	850 mm	850 mm	-	-	-	-

(*) Foundry version also available

(***) Negative quote means that working area is entirely above the floor level

Hollow Wrist robots

Decreased maintenance costs

High density automation is possible

Reliable off-line programming:
shorter application design time and
faster line start-up

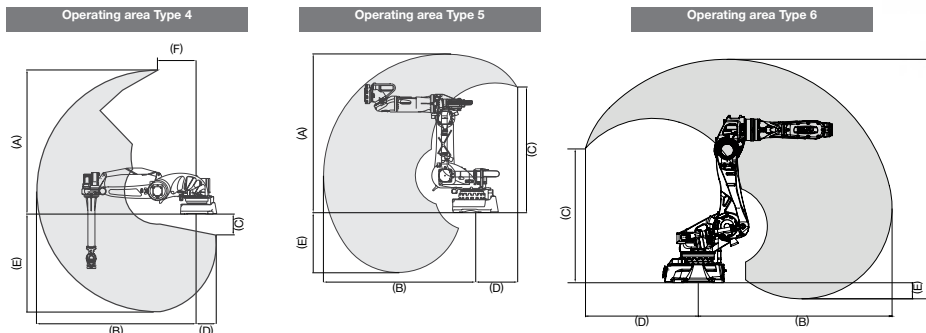

New Welding Gun

- Robotic versions
- Comau patented system
- Standard arm library
- Reduced quantity of spare parts
- No external cables
- Mountable on any robot brand
- Full range of force application covered by a single body
- Extensive standardization of components, reducing inventory cost, lead time
- Effective Digital Twin
- Fully integrated on Comau N-Series and NJ4 robots (welding machine)
- X & C type

Basic Configuration

- Comau Servo Actuator
- MFDC transformer for steel joint
- Robifix multi-contact primary power connection
- Connection Box for I/O management
- Distributor for water connection
- Bracket Standard types (for fixing the gun to the robot flange)
- Secondary voltage feedback for adaptive quality system (for steel)

Options

- Custom “Product / Process” special arms
- Special bracket design
- UL compliant Modular Covers

Specifications

Design life	30 Mil. cycles
MTTR	10 minutes
Cooling requirement	8 l/min series circuit



Quick arm exchange is facilitated thanks to the new design featuring a dedicated clamp and modified gun arm structure

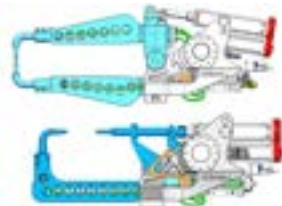

The transformation from X to C (and vice versa) is fast and easy. Simply change a single module, pulley and belt.

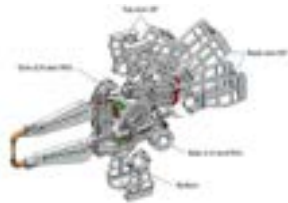

Universal mounting positions: top, back, bottom, side, 30° and 60°

AGV & AMR (Autonomous Mobile Robots)



Model	MyMR-300	MyMR-500	MyMR-1500
External Dimensions	815 x 580 x 297 mm (L x W x H)	1650 x 950 x 297 mm (L x W x H)	1415 x 1078 x 302 mm (L x W x H)
Max Payload	300 Kg	500 Kg	1500 Kg
Weight	130 Kg	190 Kg	265 Kg
Drive Configuration	Differential	Differential	Differential
Max Speed	2 m/s	1.5 m/s	1.5 m/s
Turning Radius	Turn in place ability 475 mm sweep area radius	Turn in place ability 860 mm sweep area radius	Turn in place ability 837 mm sweep area radius
Position Accuracy	+/- 1 cm, +/- 1 deg	+/- 1 cm, +/- 1 deg	+/- 1 cm, +/- 1 deg
Operating Environment	Indoor	Indoor	Indoor
Battery	Li-Ion	Li-Ion	Li-Ion
Charge Time	2 hrs from 0% to 80%	2 hrs from 0% to 80%	2 hrs from 0% to 80%
Nominal Run Time	10 hrs	8 hrs	14 hrs
Navigation System	Natural Navigation	Natural Navigation	Natural Navigation

Load type: application specific with standard and custom on top loading, conveyor and lift.

Model	Agile2500
External Dimensions	3903 x 1414 x 400 mm (L x W x H)
Weight	1500 Kg
Max Payload	2500 Kg
Max Speed	1.0 m/s in all directions (including crabbing)
Navigation Type	Natural; Reflector
Maximum ramp grade	1%
Operating Environment	Indoor
Battery Type	Lithium
Battery characteristics	25.6 Vdc - 204 Ah
Implements interfacing and communication	
Power supply	24 Vdc Power, 24 Vdc Auxiliary
Communication	CANopen fieldbus, TCP/IP

Auxiliary Equipment

Control units



Model	R1C-4 / R1C-6
Dimensions (WxDxH):	427x498x266 mm
Weight:	23 kg
Working temperature:	5 to 45°C
Humidity:	from 5% to 95% without condensation
Extended line power range:	230V ±10%
Available for:	R1C-4 > Rebel-S6 R1C-6 > Racer-3/5
SAFE Control:	available version



Model	CSCompact Plus
Dimensions:	582Hx470Wx531D mm
Weight:	44 KG
Working temperature:	5° to 45° C - 41° to 113° F
Humidity:	from 5% to 95% without condensation
Power supply:	from 400 to 480 V
Available for:	Racer 7 - S-family
Cabinet protection:	IP54
Rear compartment protection:	IP 2x
SAFE Control:	available version



Model	CSG Plus Rel.3
Dimensions:	1110Hx800Wx510D mm
Weight:	109 KG
Working temperature:	5° to 45° C - 41° to 113° F
Humidity:	from 5% to 95% without condensation
Power supply:	from 400 to 480 V
Available for:	Racer-7, NS, NJ, NJ4 / PAL (all models)
Cabinet protection:	IP54
Rear compartment protection:	IP 2x
SAFE Control:	available version

Teach Pendant



Big Screen 10"
3D integration
Simplified programming
Improved usability
Web ready
Advanced features



Display 7" WIDE touch"
Standard features
Light Weight
Easier for left handed
Expert programmer ready

Double action vertical positioners

Model	PTDV-500	PTDV-750	PTDV-850
	1.2 - 2.0	1.2 - 2.0	1.2 - 2.5
Payload	2x500 kg	2x750 kg	2x850 kg
Static torque on main axis	1000 Nm	1000 Nm	1000 Nm
Approx. time for 180° changeover	4.9 s	4.7 s	4.8 s



Double action horizontal positioners

Model	PTDO-750-1.2		
	2.0	4.0	4.5
Payload	2x750 kg		
Static torque on main axis	1000 Nm		
Approx. time for 180° changeover	3.7 s		



Orbital single lathe positioner

Model	PTS-ORB-1000
Payload	1000 kg
Max inertia	400 kgm²
Static torque on main axis	1000 Nm



Positioner modules

Model	MP-500	MP-1000	MP-1250	MP-2500
Payload	500 kg	1000 kg	1250 kg	2500 kg
Max inertia	250 kgm²	400 kgm²	400 kgm²	1100 kgm²
Static torque on main axis	600 Nm	1000 Nm	1500 Nm	5000 Nm



Rotary tables

Model	New!		
	TR-4500	RT-1500	RT-3000
Payload	4500 kg	1500 kg	3000 kg
Max inertia	7000 kgm²	780 kgm²	4300 kgm²
Static torque on main axis	4250 Nm	1100 Nm	4500 Nm



Slides

Robot model	FROM NJ-16-3,1 TO NJ-650-2,7
Rail type	TMF4B
Robot mounting position*	0° - 90° - 180° - 270°
Robot Spacer	200 - 300 - 400 - 500 mm
Dressing type Spot (S) / Hand (H)	S / H
Min. net stroke / Step - Single carriage	1510 / 1000
Min. net stroke / Step - Double carriage	760 / 1000

(*) for robot mounting positioning 0° a robot spacer is mandatory



Standard Cells and Robotic Solutions

Modular Standard Cells:

- Available Applications: Palletization, Depalletization, Arc welding, Laser Welding, Spot welding and Handling.
- Ready to Use: the cells are entirely tested and validated to guarantee full functionality before shipped to the customer's site



Custom advanced robotic solutions:

- Development of custom solution to solve Advanced Robotic applications.
- Example: MR4Weld: Mobile robotic solutions for welding in naval environment. Innovative outdoor automation solution to improve quality, performance and well-being during labor-intensive welding activities.

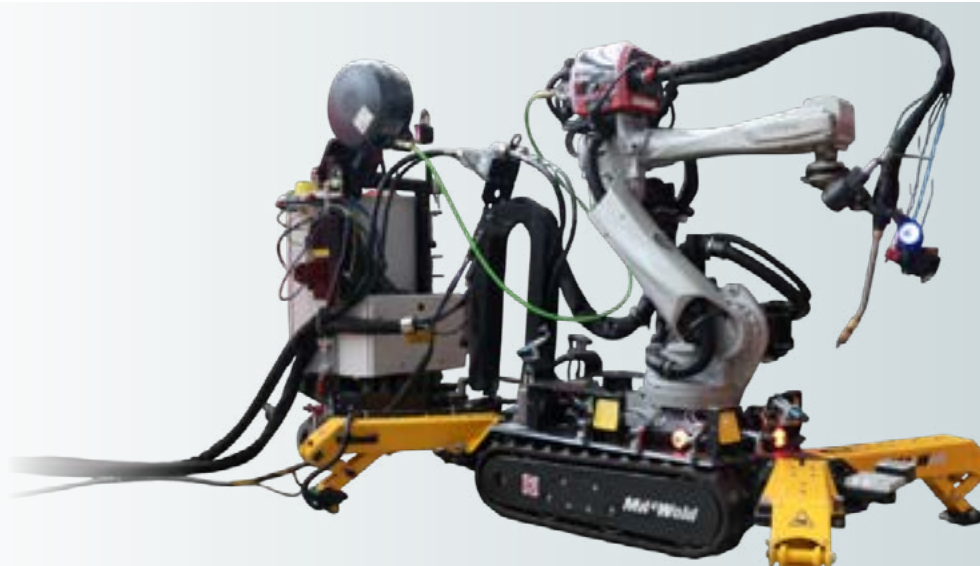



[comau.com](https://www.comau.com)

Follow us



The contents of this brochure are supplied for general information only. Comau S.p.A. reserves the right to alter specifications at any time without notice for technical or commercial reasons. The illustration does not necessarily show the products in their standard version. Edition - 03/26 - Turin.

Made in Comau